

【80*80*25mm IP68 series】

一般仕様

ベアリングタイプ	2Ball	-
回転数偏差	±10%	-
フレームタイプ	リブ	フランジ
フレーム材質	樹脂(UL 94V-0)	
羽材質	樹脂(UL 94V-0)	
期待寿命(L10残存率90%)	4万時間以上/ 60度	
保護機能	拘束時過電流保護	
	逆接続時保護	

オプション機能

回転数制御	PWM制御
	外部DC電圧制御
センサー出力	パルスセンサー
	ロックセンサー

信頼性

動作温度範囲	-10°C~70°C(5%~90% RH)		
保存温度範囲	-40°C~70°C(5%~95% RH)		
ESD ①	Class III		
絶縁階級 ②	Class A		
安全規格	UL	TUV	CE
防塵防水規格	IEC60529		

①-Reference Standard: IEC61000-4-2

②-Reference Standard: UL1446

AIR FLOW/STATIC-PRESSURE

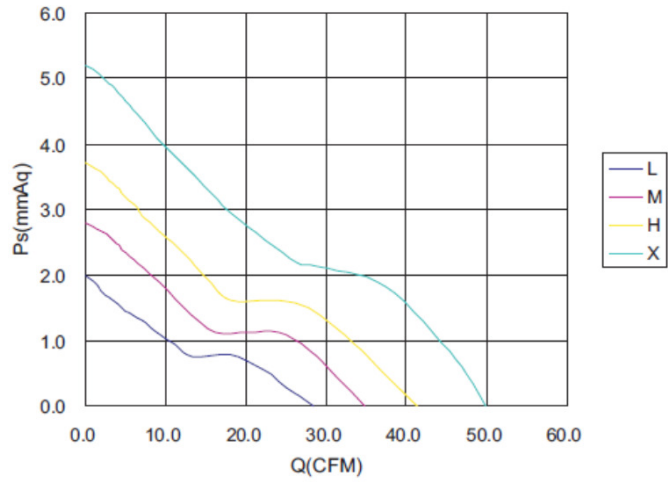

OUTLINE(mm)

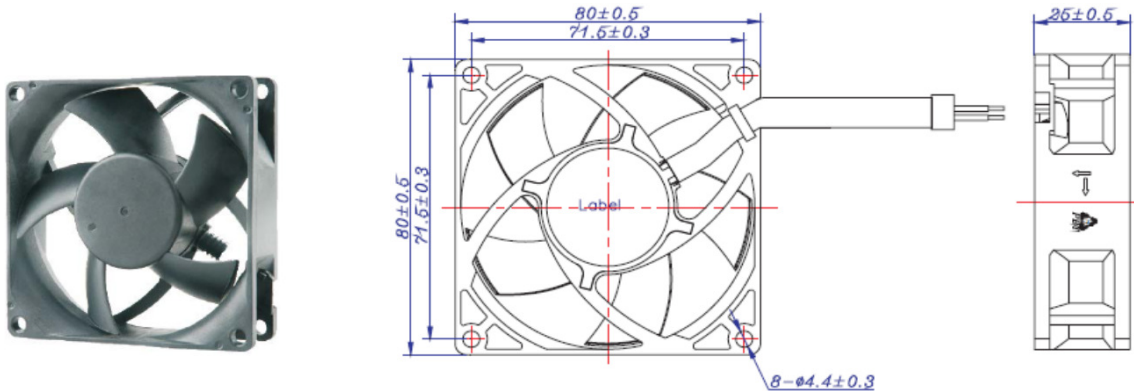

Item No.	Operating Voltage	Maximum Air Flow		Maximum Air Pressure			Speed	Rated Current	Actual Current	Input Power	Actual Power	Noise	Weight
	(V)	(CMM)	(CFM)	(Pa)	(mmAq)	(inchAq)	(rpm)	(A)	(A)	(W)	(W)	dB(A)	(g)
MGA8012LB-O25-IP68	12	0.806	28.46	19.42	1.98	0.078	2,100	0.12	0.07	1.44	0.80	23.1	90
MGT8012LB-O25-IP68	12	0.806	28.46	19.42	1.98	0.078	2,100	0.12	0.07	1.44	0.80	23.1	90
MGT8012LB-R25-IP68	12	0.806	28.46	19.42	1.98	0.078	2,100	0.12	0.07	1.44	0.80	23.1	90
MGT8012LB-W25-IP68	12	0.806	28.46	19.42	1.98	0.078	2,100	0.12	0.07	1.44	0.80	23.1	90
MGA8012MB-O25-IP68	12	0.987	34.85	27.37	2.79	0.11	2,500	0.15	0.10	1.80	1.21	29.0	90
MGT8012MB-O25-IP68	12	0.987	34.85	27.37	2.79	0.11	2,500	0.15	0.10	1.80	1.21	29.0	90
MGT8012MB-R25-IP68	12	0.987	34.85	27.37	2.79	0.11	2,500	0.15	0.10	1.80	1.21	29.0	90
MGT8012MB-W25-IP68	12	0.987	34.85	27.37	2.79	0.11	2,500	0.15	0.10	1.80	1.21	29.0	90
MGA8012HB-O25-IP68	12	1.171	41.34	36.40	3.71	0.146	3,000	0.24	0.17	2.88	2.05	33.2	90
MGT8012HB-O25-IP68	12	1.171	41.34	36.40	3.71	0.146	3,000	0.24	0.17	2.88	2.05	33.2	90
MGT8012HB-R25-IP68	12	1.171	41.34	36.40	3.71	0.146	3,000	0.24	0.17	2.88	2.05	33.2	90
MGT8012HB-W25-IP68	12	1.171	41.34	36.40	3.71	0.146	3,000	0.24	0.17	2.88	2.05	33.2	90
MGA8012XB-O25-IP68	12	1.413	49.89	50.91	5.19	0.204	3,600	0.39	0.25	4.68	2.96	37.3	90
MGT8012XB-O25-IP68	12	1.413	49.89	50.91	5.19	0.204	3,600	0.39	0.25	4.68	2.96	37.3	90
MGT8012XB-R25-IP68	12	1.413	49.89	50.91	5.19	0.204	3,600	0.39	0.25	4.68	2.96	37.3	90
MGT8012XB-W25-IP68	12	1.413	49.89	50.91	5.19	0.204	3,600	0.39	0.25	4.68	2.96	37.3	90
MGA8024LB-O25-IP68	24	0.806	28.46	19.42	1.98	0.078	2,100	0.09	0.05	2.16	1.25	23.1	90
MGT8024LB-O25-IP68	24	0.806	28.46	19.42	1.98	0.078	2,100	0.09	0.05	2.16	1.25	23.1	90
MGT8024LB-R25-IP68	24	0.806	28.46	19.42	1.98	0.078	2,100	0.09	0.05	2.16	1.25	23.1	90
MGT8024LB-W25-IP68	24	0.806	28.46	19.42	1.98	0.078	2,100	0.09	0.05	2.16	1.25	23.1	90
MGA8024MB-O25-IP68	24	0.987	34.85	27.37	2.79	0.11	2,500	0.11	0.09	2.64	2.14	29.0	90
MGT8024MB-O25-IP68	24	0.987	34.85	27.37	2.79	0.11	2,500	0.11	0.09	2.64	2.14	29.0	90
MGT8024MB-R25-IP68	24	0.987	34.85	27.37	2.79	0.11	2,500	0.11	0.09	2.64	2.14	29.0	90
MGT8024MB-W25-IP68	24	0.987	34.85	27.37	2.79	0.11	2,500	0.11	0.09	2.64	2.14	29.0	90
MGA8024HB-O25-IP68	24	1.171	41.34	36.40	3.71	0.146	3,000	0.16	0.11	3.84	2.64	33.2	90
MGT8024HB-O25-IP68	24	1.171	41.34	36.40	3.71	0.146	3,000	0.16	0.11	3.84	2.64	33.2	90
MGT8024HB-R25-IP68	24	1.171	41.34	36.40	3.71	0.146	3,000	0.16	0.11	3.84	2.64	33.2	90
MGT8024HB-W25-IP68	24	1.171	41.34	36.40	3.71	0.146	3,000	0.16	0.11	3.84	2.64	33.2	90
MGA8024XB-O25-IP68	24	1.413	49.89	50.91	5.19	0.204	3,600	0.23	0.15	5.52	3.67	37.3	90
MGT8024XB-O25-IP68	24	1.413	49.89	50.91	5.19	0.204	3,600	0.23	0.15	5.52	3.67	37.3	90
MGT8024XB-R25-IP68	24	1.413	49.89	50.91	5.19	0.204	3,600	0.23	0.15	5.52	3.67	37.3	90
MGT8024XB-W25-IP68	24	1.413	49.89	50.91	5.19	0.204	3,600	0.23	0.15	5.52	3.67	37.3	90